

Hanna DSI

Service Manual

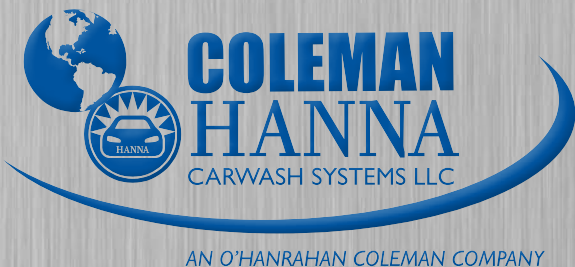

5842 W 34th St, Houston, TX 77092
1.800.999.9878 • 1.713.683.9878
www.colemanhanna.com



Find us on Facebook:
[/ColemanHannaCarwash](https://www.facebook.com/ColemanHannaCarwash)

HANNA DSI PUMP STAND

Table of Contents

DSI Chemical Injection system	2
Installation of Equipment.....	2
Description of Operation	3
Injector Chart	3
Trouble Shooting on DSI System.....	4
Picture of DSI solenoid Board.....	5
Picture of DSI pumping unit	6
Chem Flex Injectors dilution Ratio Chart.....	7
Venturi Injectors	8
Pressure Drop of Tubing.....	9
Flint and Walling Pump.....	10-24
Plumbing Diagram of DSI pump	24
Wiring Diagram of DSI	25
Warranty.....	26

Installation of equipment

The Hanna DSI unit has two basic components. The first component is the pump stand with the Electrical control cabinet. You can mount this to the wall using fasteners based upon the wall construction. Make sure you mount the pump stand in a location that is accessible for the electrician and plumber.

1. Have your electrician bring in 3 phase power to the top of the contactor inside the electrical control cabinet. The pump stand is built and wired for either 230 v or 460v based upon what was ordered. Have your electrician bring in the appropriate 208-230v or 460v depending what you ordered. You can look at the serial number tag to determine the correct voltage.
2. Have your plumber bring in a 1" water line with a valve into the inlet of the pump stand. The water line must have water pressure of 20 - 80 psi.
3. Slowly turn on the water and flush out the lines before you connect the hose to the pump.
4. After connecting the water line to the pump then slowly turn on the water and allow the water to flow thru the pump. Flush water thru the pump for about 2 minutes to make sure all of the air is out of the pump.
5. Once you have water connected and the pump flushed then you can turn on the power to the control cabinet and press the contactor inside the Electrical control cabinet and check for rotation. If the pump is rotating backwards have the electrician change the wiring to reverse rotation. If the pump is running the correct rotation then press the contactor for about one minute to allow the pump to run with the water on the flush out the lines.
6. Now you can mount the Solenoid board. Some units have one or two solenoid boards depending on the size of the location and chemical requirements. Mount the Solenoid board on the wall and run the hose from the discharge of the pump to the inlet of the water manifold. You will also need to provide a 1/2" air line to the air manifold on the board.
7. Now you can run 1/2" poly flow tubing (customer supplied) from each injector to each arch or foaming puck.
8. If you are running to a Versa Arch then you will need to install a tee in the line down stream from the water solenoid and connect the chemical line from the solenoid board to this tee.
9. If you are running to a foaming device such as a Hockey puck or Wall of Foam then you will need to run an air line as well.
10. Hanna recommends using a 1 gpm injector for arches and you can select the dilution tip to determine the correct dilution. You will need to check with you chemical supplier to determine how much chemical is recommended for each vehicle.
Example: Presoak chemical recommended strength for one supplier was 5 oz per vehicle. The Versa arch uses 11 gpm and the arch is on for 30 seconds per vehicle.
 $11 \text{ gpm} = 1408 \text{ ounces per minute or } 704 \text{ per } 30 \text{ seconds. } 704 \text{ divided by } 5 \text{ oz} = 140 \text{ to } 1.$ You can use a copper or Pumpkin tip to start testing.
11. Now you can run the low voltage wiring from the tunnel controller to the Electrical control box. There is a terminal strip on the right hand side that you will connect the 24v signal from the tunnel controller to. See attached wiring diagram.

Description of Operation

The DSI system consist of a 3 hp pump or sometimes a 2 hp based upon the flow requirements of the system. The system includes a pressure regulator. We recommend that the pressure is set at 150 psi. Do not exceed 190 psi on this system. When the pump is running excess water from the pump regulator is being returned back to the inlet.

The tunnel controller controls the 24v signal to open up the water solenoid and air solenoid to deliver water to the injector and the solenoid manifold. Each function has a separate solenoid that turns on when the tunnel controller tells it to. The pump turns on and the correct solenoid opens up and delivers water thru the injector. The injectors come in different sizes and have metering tips to dilute the chemical to the proper dilution. Look at the chart below to see the different chemical injectors and the different metering tips. The injector creates the suction to draw the chemical. The Injectors are available in different sizes based upon flow rates. The chart below shows the recommended injector for the Hanna Tunnel equipment. Each injector has a suction hose and hose barb. When you pull off the suction hose you can screw in a metering tip to change the dilution of the chemicals. There are two styles of tips that are available the standard lean tips and the Ultra Lean tips. The injector flow rate is sized to be less than the cumulative flow thru the tips or nozzles for that function. If the cumulative flow of the nozzles is less than the flow rate of the injector it will not work or draw chemical properly. This creates back pressure and stops the suction.

The dilution that you get with your chemicals will vary based upon the viscosity of the chemicals. Your Chemical supplier will set up your machine with the proper tips and dilution ratios for the chemicals you are using. Most foamers are direct injection and the air solenoid on the board will deliver air to the Foamer. Most arches are set up to be down stream injection. A typical Hanna arch delivers 11 gpm so you will need a water solenoid to turn on the water to the arch. The DSI system will inject the chemical down stream of the water solenoid.

DSI System on Hanna Equipment

Product Name	HFI Injector Color	HFI Injector Size - GPM		
Chemical Tire Cleaner	Red	1.0 GPM		Direct Injection
Presoak Arch	Red	1.0 GPM		Down stream injection
Wall of Foam	Dark Green	5.5 GPM		Direct Injection
Wall of Foam using 3 injectors	Orange	1.5 GPM		Direct Injection
Triple Foam using Hockey puck Foamers	Red	1.0 GPM		Direct Injection
Top Brush Soap	Red	1.0 GPM		Down stream injection
Drying agent arch	Red	1.0 GPM		Down stream injection
Sealer Wax arch	Red	1.0 GPM		Down stream injection
	Grey	2.0 GPM		
	Blue	2.25 GPM		
	Light Green	3.25 GPM		

Troubleshooting the DSI System

Chemical is not being drawn up the suction tube.

1. Go to the arch or Foamer and turn on the product that you are having a problem with.
2. Does water flow out the tips on the arch or Foamer?
3. If yes then the water solenoid is on and water is flowing through the injector.
4. Pull off the suction hose on the chemical and remove the lean or ultra-lean tip. Make sure the lean or ultra-lean tip is not clogged. Check to see that all of the nozzles are spraying properly and not causing back pressure. Clean Nozzles as required.
5. The best method is to install a vacuum gauge with a short hose on the hose barb and see if the injector is creating suction. If you have 20" of suction then the injector is working properly and the lean tip is clogged or the chemical is too thick to draw properly.
6. If you are not getting any suction or less than 10" there are two causes of the problem. The injector has to flow the proper amount of water to create the suction. If the device is a Faomer then take the Foam Generator apart and clean the mesh inside and reassemble and test again.

Example:

If the injector is Red and is sized for 1.0 gallons per minute the tips on the arch or Foamer have to be sized to flow at least 1.0 gpm. If the tips is clogged then the tips are only flowing .8 gpm and then the injector will not create any suction.

- a. Check to see if the injector is clogged
- b. If no tips are clogged then go to the Arch and remove one of the tips and turn on and see if the injector has suction.
- d. Under the barb of the injector is a built in check valve with Teflon ball and spring.
- e. Remove the barb very carefully to make sure you don't lose the ball, spring or o-ring and clean as necessary.

Notes: When technicians are having a problem with the injector not drawing up the correct amount of chemical they usually want to increase the size of the injector. This does not solve the problem and only makes the problem worse. The tips or Foamer have to be sized to dispense more water that the injector is rated to flow. If the tips are too small then there will be back pressure and it will cause the injectors to stop drawing chemicals.

Tip Color	Ratio	Style	Tip Color	Ratio	Style
Copper	230:1	Ultra Lean	Green	16:1	Lean
Pumpkin	175:1	Ultra Lean	Blue	13:1	Lean
Burgundy	143:1	Ultra Lean	Yellow	9:1	Lean
Lime	100:1	Ultra Lean	Black	6:1	Lean
Tan	102:1	Lean	Purple	15:1	Lean
Orange	75:1	Lean	Gray	4:1	Lean
Turquoise	60:1	Lean	None	3.6 :1	Lean
Pink	43:1	Lean			
Light Blue	33:1	Lean			
Brown	28:1	Lean			
Red	22:1	Lean			
White	18:1	Lean			

Ratio is based upon water thin products. Field test to determine the actual ratio. See attached dilution chart from HFI for complete dilution ratios.

Solenoid Board with 7 water solenoids and injectors

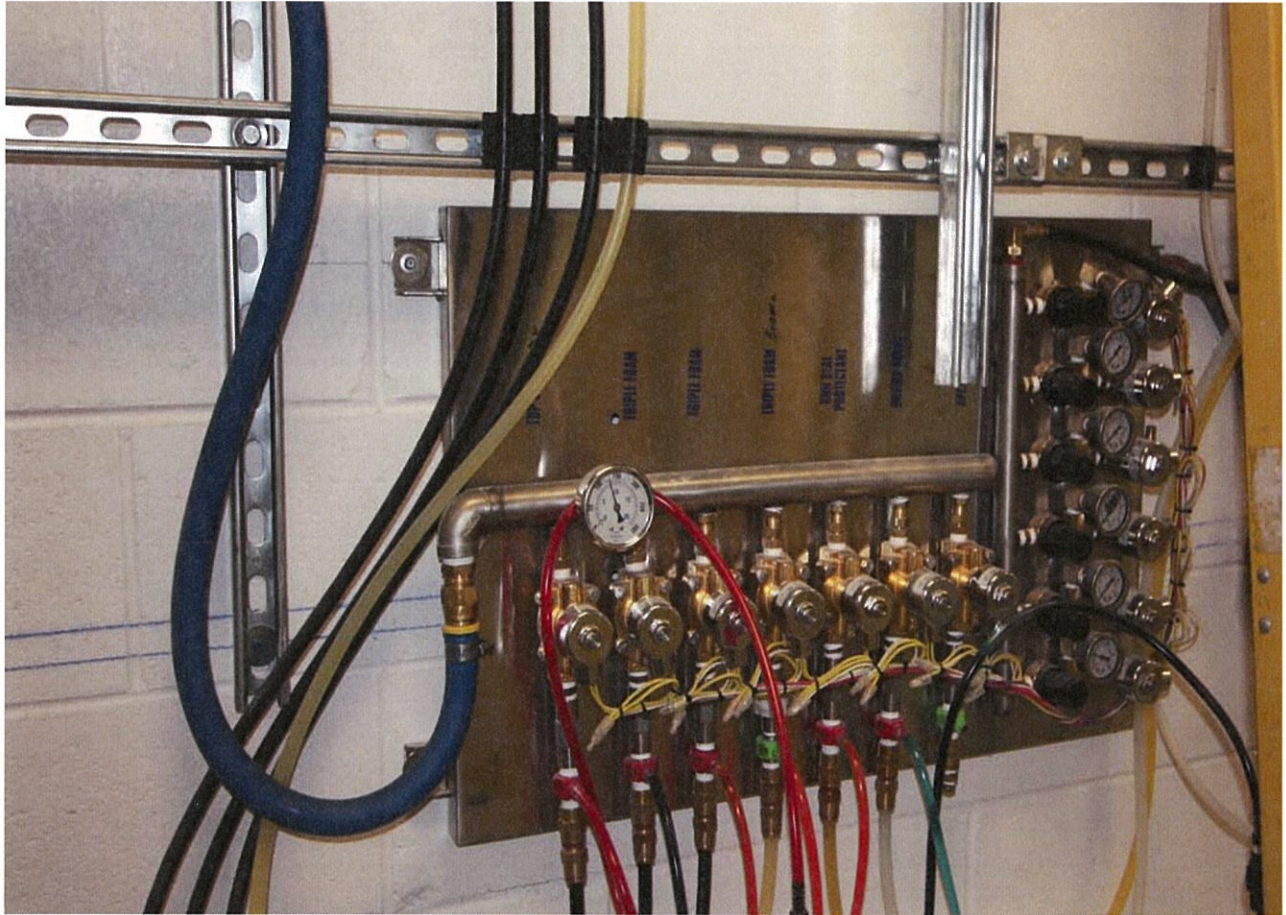

Insert picture of electrical control cabinet and pump

CHEM-FLEX™ INJECTORS

CHEMICAL DILUTION RATIOS

(Assumes feed pressure of 200 PSI)

		#8-32 METERING TIPS								
Flow Rate (GPM) at 200 PSI		0.25	0.50	0.75	1.00	1.50	2.00	2.25	3.25	5.50
Injector Color →		White	Yellow	Tan	Red	Orange	Gray	Blue	Light Green	Dark Green
Nozzle Size →		0.029" (0.7 mm)	0.040" (1.0 mm)	0.051" (1.3 mm)	0.057" (1.4 mm)	0.070" (1.8 mm)	0.083" (2.1 mm)	0.086" (2.2 mm)	0.098" (2.5 mm)	0.125" (3.2 mm)
Metering Tip	Copper	1: 57	1: 104	1: 155	1: 195	1: 281	1: 406	1: 468	1: 629	1: 1074
	Pumpkin	1: 43	1: 82	1: 119	1: 126	1: 238	1: 348	1: 396	1: 554	1: 946
	Burgundy	1: 34	1: 67	1: 97	1: 111	1: 207	1: 304	1: 347	1: 495	1: 845
	Lime	1: 28	1: 57	1: 81	1: 100	1: 183	1: 270	1: 307	1: 447	1: 764
	Tan	1: 28	1: 57	1: 81	1: 100	1: 183	1: 270	1: 307	1: 447	1: 764
	Orange	1: 23	1: 44	1: 64	1: 78	1: 137	1: 196	1: 215	1: 314	1: 536
	Turquoise	1: 17	1: 31	1: 45	1: 55	1: 91	1: 126	1: 134	1: 197	1: 336
	Pink	1: 14	1: 24	1: 35	1: 42	1: 68	1: 93	1: 98	1: 143	1: 224
	Light Blue	1: 11	1: 17	1: 24	1: 31	1: 47	1: 64	1: 66	1: 98	1: 166
	Brown	1: 10	1: 15	1: 22	1: 26	1: 43	1: 58	1: 59	1: 88	1: 150
	Red		1: 12	1: 17	1: 23	1: 34	1: 45	1: 46	1: 69	1: 116
	White		1: 12	1: 16	1: 22	1: 31	1: 42	1: 43	1: 64	1: 108
	Green		1: 11	1: 14	1: 20	1: 28	1: 37	1: 38	1: 55	1: 94
	Blue		1: 10	1: 12	1: 17	1: 23	1: 30	1: 31	1: 46	1: 77
	Yellow			1: 9	1: 12	1: 16	1: 20	1: 22	1: 31	1: 52
	Black				1: 10	1: 13	1: 16	1: 17	1: 24	1: 40
	Purple				1: 6.6	1: 8.3	1: 9	1: 10	1: 13	1: 21
Gray				1: 5.3	1: 6.7	1: 6.9	1: 7.6	1: 10	1: 16	
Open				1: 4.9	1: 5.3	1: 5.2	1: 6.0	1: 6.1	1: 10	

		SPIRAL METERING PLUGS								
Flow Rate (GPM) at 200 PSI		0.25	0.50	0.75	1.00	1.50	2.00	2.25	3.25	5.50
Injector Color →		White	Yellow	Tan	Red	Orange	Gray	Blue	Light Green	Dark Green
Nozzle Size →		0.029" (0.7 mm)	0.040" (1.0 mm)	0.051" (1.3 mm)	0.057" (1.4 mm)	0.070" (1.8 mm)	0.083" (2.1 mm)	0.086" (2.2 mm)	0.098" (2.5 mm)	0.125" (3.2 mm)
Spiral Plug Length	3.00"	1: 251	1: 503	1: 754	1: 1036	1: 1509	1: 2012	1: 2263	1: 3269	1: 5532
	2.00"	1: 181	1: 363	1: 544	1: 726	1: 1089	1: 1451	1: 1633	1: 2359	1: 3991
	1.00"	1: 104	1: 208	1: 311	1: 415	1: 623	1: 831	1: 934	1: 1350	1: 2284
	0.75"	1: 82	1: 165	1: 247	1: 329	1: 494	1: 659	1: 741	1: 1071	1: 1812
	0.50"	1: 59	1: 119	1: 178	1: 238	1: 357	1: 475	1: 535	1: 772	1: 1307
	0.25"	1: 34	1: 68	1: 102	1: 136	1: 204	1: 272	1: 306	1: 442	1: 748

NOTE: Dilution ratios given above are based on drawing water through the metering tips and are meant as a starting point for system configuration. Results are expected to vary when drawing chemicals due to differences in viscosity and temperature.

VENTURI INJECTORS

THE SCIENCE BEHIND IT

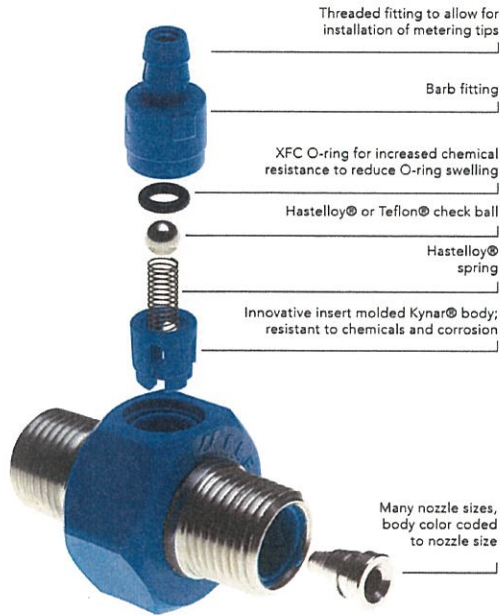

HOW IT WORKS:

The Venturi injector eliminates the need for bulky mixing tanks. As water flows into the cone-shaped nozzle, the velocity increases. As velocity increases, the pressure decreases - creating a vacuum that pulls the precise amount of chemical into the chamber and mixes it with water.

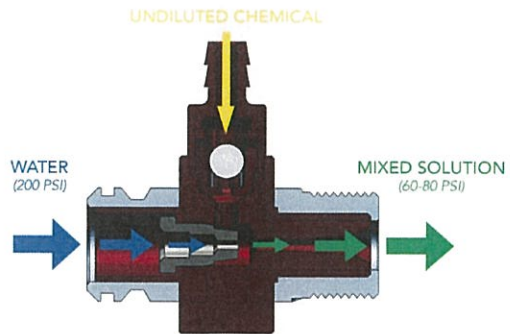

Single Hose Barb:
For diluting one chemical with water.

Dual Hose Barb:
For diluting two chemicals with water. Ideal for adding a color or scent to your solution.

Triple Hose Barb:
For diluting three chemicals with water. Ideal for adding a color and scent to your solution or for on-site blending of chemistry.

SPECIFICATIONS:

Pressure Range: up to 1000 PSI Max. (69 Bar) Inlet, 333 PSI (23 Bar) Max. Outlet

Temperature Range: 33°F - 175°F (.5°C - 79°C)

Maximum Wrench Torque: 30 ft-lbs (41 N-m)

Operating Manual

Tubing Pressure Drop by Injector and tube length

1/2" ID Braided Hose

Flow Rate (Gpm) at 200 psi	Injector								
	0.25	0.50	0.75	1.00	1.50	2.00	2.25	3.25	5.50
Length	0.029	0.04	0.051	0.057	0.07	0.083	0.086	0.098	0.125
100	<1	<1	2	2	4	7	8	14	36
75	<1	<1	1	2	3	5	6	11	26
50	<1	<1	<1	1	2	4	4	8	18
25	<1	<1	<1	<1	1	2	2	4	9

1/2" OD Poly Tube

Flow Rate (Gpm) at 200 psi	Injector								
	0.25	0.50	0.75	1.00	1.50	2.00	2.25	3.25	5.50
Length	0.029	0.04	0.051	0.057	0.07	0.083	0.086	0.098	0.125
100	1	3	5	7	14	23	28	54	142
75	1	2	4	6	12	18	22	42	106
50	<1	1	3	4	8	12	15	28	73
25	<1	<1	1	2	3	6	7	13	34

3/8" OD Poly Tube

Flow Rate (Gpm) at 200 psi	Injector								
	0.25	0.50	0.75	1.00	1.50	2.00	2.25	3.25	5.50
Length	0.029	0.04	0.051	0.057	0.07	0.083	0.086	0.098	0.125
100	9	21	35	52	95	150	181		
75	7	16	27	40	74	117	142		
50	4	10	18	28	52	83	101	192	
25	2	5	8	12	23	36	44	82	

*Pressure Drop Through 100 feet of 3/4" ID Braided hose was <5 psi - Any shorter length or Lower flow injector will result in an even lower pressure drop.

Operating Instructions & Parts Manual

Please read and save these instructions. Read carefully before attempting to assemble, install, operate or maintain the product described. Protect yourself and others by observing all safety information. Failure to comply with instructions could result in personal injury and/or property damage! Retain instructions for future reference.

Pressure Booster Pumps

Description

Pressure booster pumps increase water pressure from city mains or private water systems. Applications include providing high water pressure for washing buildings, dairy walls or floors, hog parlors, poultry houses, rinsing or spray cooling equipment, lawn sprinkling and insecticide spraying.

Single-phase models are equipped with a capacitor start, thermal protected motor. Three-phase models require separate overload protection.

Unpacking

When unpacking the unit, inspect carefully for any damage that may have occurred during transit.

NOTE: Use pump with clear water only.

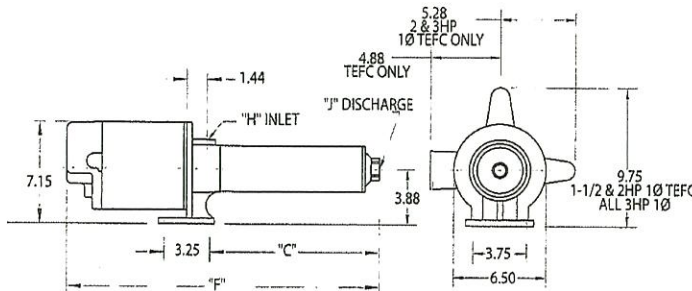

Figure 1

IL03918

Pump Dimensions 60 Hz							Chart A	
HP	GPM	Stage	"C"	F			H	J
				F&W	TEFC			
					1 Phase	3 Phase		
1/3	5	8	10.19	19.81	-	-	.75	.75
1/3*	5	8	10.19	20.06	22.04	-	.75	.75
1/2	5	12	13.38	23.25	23.23	24.10	.75	.75
1/2*	5	14	14.97	25.34	26.82	25.69	.75	.75
3/4	5	16	16.54	26.91	28.77	27.51	.75	.75
3/4	7	12	13.38	23.75	25.61	24.35	.75	.75
3/4*	7	14	14.97	25.84	27.20	25.94	.75	.75
1	10	14	16.31	27.18	29.16	28.02	.75	.75
1-1/2	10	16	18.13	29.62	31.48	30.07	.75	.75
1*	10	20	21.69	33.18	34.54	33.40	.75	.75
1*	10	22	23.50	34.99	36.35	35.21	.75	.75
1*	10	23	24.38	35.87	37.73	36.09	.75	.75
2	19	14	17.89	29.88	32.12	30.87	.75	.75
1-1/2*	19	20	24.06	36.05	37.41	36.00	.75	.75
2*	19	22	26.13	38.12	40.36	39.11	.75	.75
2	27	11	15.38	27.37	29.61	28.36	1.00	1.00
3	27	14	18.50	30.49	33.85	33.35	1.00	1.00
2*	27	17	21.59	33.58	35.82	34.57	1.00	1.00
3	27	17	21.59	33.74	-	-	1.00	1.00
2	35	6	13.94	25.93	28.17	26.92	1.00	1.00
3	35	8	17.13	29.12	32.48	31.98	1.00	1.00
1-1/2*	35	8	17.13	29.12	30.48	29.07	1.00	1.00
3*	35	14	26.86	38.85	42.21	41.71	1.00	1.00

PRESSURE ADDED - PSI†					10	20	40	60	80	100	120	140	160	180	200	220	Max. Press. PSI	Suction Pipe Tap NPT	Disch. Pipe Tap NPT
Stainless Steel Fitted	Powder-Coated Cast Iron Fitted	Cast Iron Fitted	HP	Stage	Output - Gallons per Minute														
60Hz Models																			
PB0508S031	PB0508C031	PB0508A031	1/3	8	10.2	9.6	8.3	6.5	4.3								96	3/4"	3/4"
PB0512S051	PB0512C051	PB0512A051	1/2	12	10.0	9.5	8.3	7.1	6.0	4.0	2.3						132		
PB0516S071	PB0516C071	PB0516A071	3/4	16	10.2	9.7	9.1	8.3	7.5	6.6	5.8	4.6	3.3				189		
PB0712S071	PB0712C071	PB0712A071	3/4	12	14.0	13.4	12.2	10.9	9.6	8.9	7.0	4.6					168		
PB1014S101	PB1014C101	PB1014A101	1	14	*	*	14.5	13.4	12.3	11.2	9.8	8.0	6.0	2.3			183		
PB1016S151	PB1016C151	PB1016A151	1-1/2	16	*	*	15.0	14.1	13.1	12.1	11.0	9.8	8.2	5.2	2.0		212		
PB1914S201	PB1914C201	PB1914A201	2	14	27.6	27.0	25.7	24.2	22.6	20.8	18.7	16.2	12.9	7.7			190	1"	1"
PB3506S201	PB3506C201	PB3506A201	2	6	48.0	47.0	42.5	35.2	24.0								85		
PB2711S201	PB2711C201	PB2711A201	2	11	*	*	31.5	29.5	27.1	24.2	20.3	13.0					147		
PB3508S301	PB3508C301	PB3508A301	3	8	48.0	47.5	44.0	40.0	35.2	27.5							118		
PB2714S301	PB2714C301	PB2714A301	3	14	*	*	33.0	31.5	29.8	27.9	25.6	22.8	18.9	11.1			187		
PB2717S303**	-	-	3	17	*	*	34.1	32.3	30.5	28.3	25.8	23.1	20.0	16.6	11.4		225		
-	-	PB5504A201	2	4	77.6	71.5	52.5										55	2"	2"
-	-	PB5506A301	3	6	77.8	74.4	65.0	51.1	31.9								83		
-	-	PB8504A201	2	4	105.8	90.0	47.0										49		
-	-	PB8505A301	3	5	108.8	98.8	60.0	25.0									60		

† Example: If PB0508A031 pump is connected to supply line of sufficient capacity, carrying water at 40 PSI, and the output of the pump is held to 7.3 GPM by a gate valve, the pump will add 40 PSI to line pressure for a total output pressure of 80 PSI.

* Operation of pump in this range may result in reduced pump life and/or motor damage.

To keep pump and seal lubricated, a minimum flow of 1.5 GPM must always be maintained through the pump.

** Only available in 3 phase

Motor voltage: Open Drip Proof
 Single Phase 1/3 - 2 HP - 115/230; 3 HP - 230V 60Hz.
 Three Phase 1/2 - 2 HP - 208-230/460, 50/60Hz.
 Three Phase 3 HP - 208-230/460, 60 HZ
 For three phase models, use suffix "3" on the model no.
 Example: PB0512A053

Totally Enclosed Fan Cooled
 Single Phase: 1/2 thru 3 HP - 115/230V 60/50Hz
 Three Phase: 1/2 thru 3 HP - 208/230/460V 60/50Hz

Single Phase Motor Data 60HZ							Chart C	
Single Phase† 60 Hz 3450 RPM Capacitor Start								
HP	Motor Voltage	Factory Connected Motor Voltage	Service Factor Motor Amps		Locked Rotor Motor Amps		Code Letter	
			115V	230V	115V	230V		
1/3	115/230	115V	8.6	4.3	26.0	13.0	K	
1/2	115/230	115V	13.0	6.5	36.0	18.0	K	
3/4	115/230	115V	14.0	7.0	52.0	26.0	K	
1	115/230	230V	18.0	9.0	78.0	39.0	L	
1-1/2	115/230	230V	21.0	10.5	98.0	49.0	J	
2	115/230	230V	25.0	12.5	116.0	58.0	H	
3	230	230V	-	13.5	-	53.0	D	

Single Phase Motor Data 50HZ							
Single Phase† 50 Hz 2850 RPM Capacitor Start							
1/2	115/230	115V	10.0	5.0	48.0	24.0	M
3/4	115/230	115V	14.4	7.2	64.0	32.0	L
1	115/230	230V	16.4	8.2	72.0	36.0	K
1-1/2	115/230	230V	23.6	11.8	104.0	52.0	K
2	230	230V	-	13.2	-	55.0	H

† Thermal overload protector - automatic reset

Three Phase Motor Data							Chart D
Three Phase† 60/50 Hz 3450/2850 RPM Capacitor Start							
HP	Motor Voltage	Factory Connected Motor Voltage	Service Factor Motor Amps		Locked Rotor Motor Amps		Code Letter
			230V	460V	230V	460V	
3/4	208-230/460	230V	3.5	1.75	19.0	9.5	K
1	208-230/460	230V	4.5	2.25	26.9	13.5	K
1-1/2	208-230/460	230V	5.7	2.85	33.5	16.8	K
2	208-230/460	230V	7.4	3.70	44.0	22.0	K
3††	208-230/460	230V	9.8	4.90	48.0	24.0	D

††3 HP, 3 Phase motor operable on 60Hz only.

Material Construction		Chart E
Component	Standard Models*	Stainless Steel Models
Motor	Rear access - Nema 56J face	Rear access - Nema 56J face
Bearings	Ball-ball, permanently lubricated	Ball-ball, permanently lubricated
Impellers	Noryl with 304 stainless steel bearing insert	Noryl with 304 stainless steel bearing insert
Diffuser	Noryl	Noryl
Diffuser plates	Delrin	Delrin
Pump shaft	416 Stainless steel	304 Stainless steel
Pump shaft coupling	316 Stainless steel	316 Stainless steel
Pump shell	304 Stainless steel	304 Stainless steel
Discharge & inlet casting	Cast iron	304 Stainless steel
O-Rings	Buna-N	Viton
Seal composition	Carbon-silicon carbide, stainless steel spring and Buna-N	Carbon-silicon carbide, stainless steel spring and Viton

*Models with powder coated inlet & discharge also available.

Minimum Wire Size Chart (Gauge)								Chart F
Motor HP	Volts	Phase	Distance In Feet From Motor To Service Panel					Breaker Size (Amps)
			0-50	50-100	100-150	150-200	200-300	
			Wire Size					
1/3	115/230	1	14/14	14/14	14/14	12/14	12/14	15/15
1/2	115/230	1	12/14	12/14	12/14	12/14	10/14	15/15
3/4	115/230	1	12/14	12/14	10/14	10/12	8/12	15/15
1	115/230	1	10/14	10/14	10/12	8/12	6/10	20/15
1 1/2	115/230	1	10/12	8/12	6/12	*/10	*/10	30/15
2	115/230	1	10/12	8/12	6/12	*/10	*/10	30/15
3	230	1	10	10	10	10	8	20
3/4	230/460	3	14/14	14/14	14/14	14/14	14/14	15/15
1	230/460	3	14/14	14/14	14/14	14/14	12/14	15/15
1 1/2	230/460	3	14/14	14/14	14/14	12/14	12/14	15/15
2	230/460	3	14/14	14/14	14/14	12/14	10/12	15/15
3	230/460	3	14/14	14/14	14/14	12/14	10/12	15/15

1. (*) Not economical to run in 115V, use 230V.

General Safety Information

Carefully read and follow all safety instructions in this manual and on pump. Keep safety labels in good condition. Replace missing or damaged safety labels.



This is a SAFETY ALERT SYMBOL. When you see this symbol on the pump or in the manual, look for one of the following signal words and be alert to the potential for personal injury or property damage.



Warns of hazards that WILL cause serious personal injury, death or major property damage if ignored.



Warns of hazards that CAN cause serious personal injury or death, if ignored.



Warns of hazards that MAY cause minor personal injury, product or property damage if ignored.

IMPORTANT: Indicates factors concerned with operation, installation, assembly or maintenance which could result in damage to the machine or equipment if ignored.

NOTE: Indicates special instructions which are important but are not related to hazards.



Wire motor for correct voltage. See "Electrical" section and Motor Data Charts C&D of this manual, and motor nameplate.



Hazardous voltage. Can shock, burn or cause death. Ground pump before connecting to power supply.

Ground motor before connecting to power supply.

Meet United States National Electrical Code and local codes for all wiring.

Do not handle a pump or pump motor with wet hands or when standing on a wet or damp surface or in water.



Follow wiring instructions in this manual when connecting to power lines.



Always disconnect power source before performing any work on or near the motor or its connected load.



Do not use to pump flammable or explosive fluids such as gasoline, fuel oil, kerosene, etc. Do not use in flammable and/or explosive atmospheres.



Hazardous pressure! Install pressure relief valve in discharge pipe. Release all pressure on system before working on any component.

1. Make workshop child proof - use padlocks, master switches; remove starter keys.
2. Wear safety glasses when working with pumps.
3. Wear a face shield and proper apparel when pumping hazardous chemicals.
4. Keep work area clean, uncluttered and properly lighted; replace all unused tools and equipment.
5. Provide guarding around moving parts.
6. Keep visitors at a safe distance from the work area.
7. Periodically inspect pump and system components.
8. Protect electrical cord. Replace or repair damaged or worn cords immediately.

9. Do not insert finger or any object into pump or motor openings.
10. Secure the discharge line before starting the pump. An unsecured discharge line will whip, possibly causing personal injury and/or property damage or puncture.



Do not touch an operating motor or engine. They are designed to operate at high temperatures.



This product contains chemicals known to the State of California to cause cancer and birth defects or other reproductive harm.



Risk of Electric Shock. This pump has not been investigated for use in swimming pool areas.

NOTE: Pumps with the "CSA-CUS" mark are tested to UL standard UL778 and certified to CSA standard C22.2 No. 108.

Pre-Installation

HANDLING

Avoid impact on pump or motor. In particular, avoid impact on discharge end of pump or rear motor access cover.

LOCATION



In any installation where property damage and/or personal injury might result from an inoperative or leaking pump due to power outages, discharge line blockage, or any other reason, a backup system(s) should be used.

1. Locate pump as close to the fluid source as possible, keeping the inlet pipe short as possible.
2. Place unit where the pump and piping are protected from the weather and extremes of heat, humidity and below freezing temperatures.
3. Mount unit in a dry location that is easily accessible for inspection and maintenance. If a dry location is not available, mount it on a foundation well above the wet floor.
4. Allow ample clearance around unit for free air circulation.

SUCTION LIMITATIONS

1. Units are non self-priming.
2. Pressure booster pumps are not recommended for suction lift applications.

PIPING

1. Use galvanized piping, rigid plastic or other suitable pipe that will not collapse under suction or rupture due to pressure.



If hose is used, make sure it is the reinforced industrial type that is rated higher than the shutoff pressure of the system. Ordinary garden hose will collapse and starve the pump of water.

2. The diameter of the inlet and discharge pipe should be no smaller than the corresponding ports of the pump (See Figure 1). Smaller pipe will reduce the capacity of the pump. Increase pipe size on long runs.
3. Avoid air pockets in inlet piping or air will accumulate at high points, making priming difficult.
4. Use pipe compound on all joints and connections. Use Teflon tape or plastic joint stik, on plastic pipe. Draw all pipe up tightly.

IMPORTANT: The entire system must be air and water tight for efficient/ proper operation.

**Installation
PUMP INSTALLATION**

IMPORTANT: Pump is built to handle clear water only; it is not designed to handle water containing sand, silt or other abrasives.

1. Refer to Figures 6, 7, and 8 for typical installations.

CAUTION Support pump and piping when assembling and when installed. Failure to do so may cause piping to break, pump to fall, motor bearing failures, etc.

2. If the pump is used as part of a permanent installation, bolt to a rigid foundation.

WARNING Use only components that are rated for maximum pressure pump can produce when used in boosting system or any other system. Do not exceed the total maximum pressure boost as listed per model in Performance Charts B.

PRESSURE BOOST SYSTEMS

1. On pressure boost systems, locate the pump so that there will always be a positive supply of water to the pump (See Figures 6, 7 and 8).
2. For service convenience, install a gate valve and union in the inlet and discharge line.

CAUTION Do not use a globe valve or other restricting type of valve that will seriously restrict the pumps discharge capacity.

3. Install a check valve as shown in Figure 6. Be sure check valve flow arrows point in the direction of water flow.
4. Whenever dirt, sand or debris is present in the supply water, install a strainer or filter on the inlet side of the pump (See Figure 7).

NOTE: For heavy amounts of sediment, install a trap filter on the inlet side of the pump (See Figure 5).

NOTE: Pressure gauges installed before and after the filter will show pressure differential indicating the need for filter replacement or cleaning.

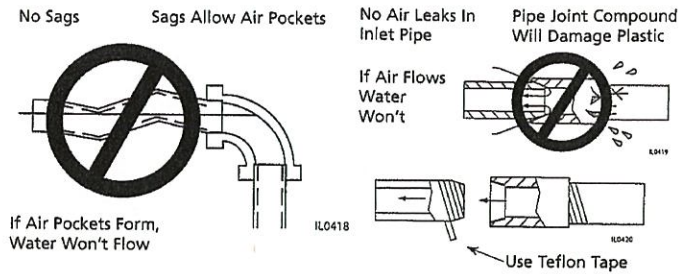

Figure 2 - No Air Pockets in Inlet Pipe

Figure 3 - Inlet Pipe Must Not Leak

CAUTION Mount pump in correct position or pump failure will result.

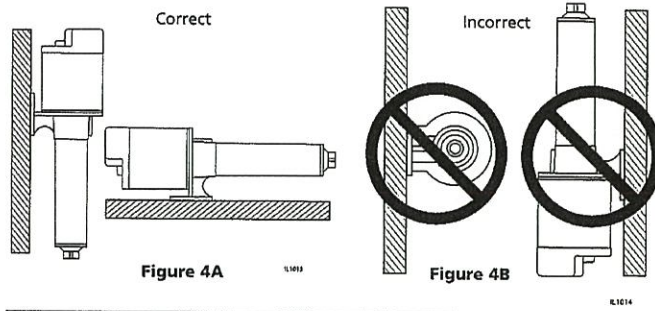

Figure 4A

Figure 4B

SAND AND SEDIMENT TRAP FILTER

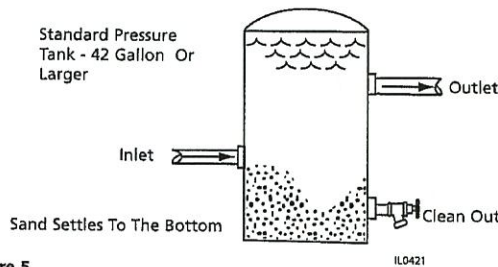

Figure 5

IMPORTANT: Clean all filters and strainers on a regular schedule.

Installation (Continued)

5. A pressure gauge installed in the inlet pipe close to the inlet port, (See Figure 6) will show if enough water is being supplied to the pump. See Operation Section - Priming, Pressure Boost Installations.
6. On installations that are using nozzles for mist spraying, install a filter in the discharge plumbing to prevent the nozzles from becoming plugged. Multiple filters should be plumbed in parallel.

WARNING *Install a pressure relief valve on any installation where pump pressure can exceed the pressure tank's maximum working pressure or on systems where the discharge line can be shut off or obstructed. Extreme over pressure can result in personal injury or property damage.*

CAUTION *This unit is not waterproof and is not intended to be used in showers, saunas or other potentially wet locations. The motor is designed to be used in a clean dry location with access to an adequate supply of cooling air. Ambient temperature around the motor should not exceed 104°F (40°C). For outdoor installations, motor must be protected by a cover that does not block airflow to and around the motor. This unit is not weatherproof nor is it able to be submerged in water or any other liquid.*

⚠ *To avoid dangerous or fatal electrical shock, turn off power to motor before working on electrical connections.*

⚠ *Supply voltage must be within ± 10% of nameplate voltage. Incorrect voltage can cause fire or seriously damage motor and voids warranty. If in doubt, consult a licensed electrician.*

⚠ *Use wire size specified in wiring Chart F. If possible, connect pump to a separate branch circuit with no other appliances on it. If motor wiring diagram differs from diagram shown below, follow diagram on motor.*

Pump used to boost incoming city pressure (automatic operation).

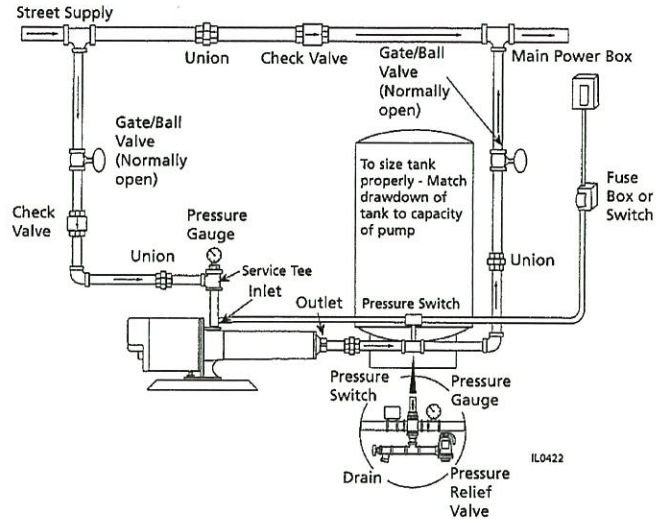

Figure 6

IMPORTANT: A contained air pressure tank and pressure switch is required to keep the pump from rapid cycling and prevent the motor from over heating. Install the tank and switch on the house side of system.

Pump used to boost water pressure in mist spray applications (automatic operation).

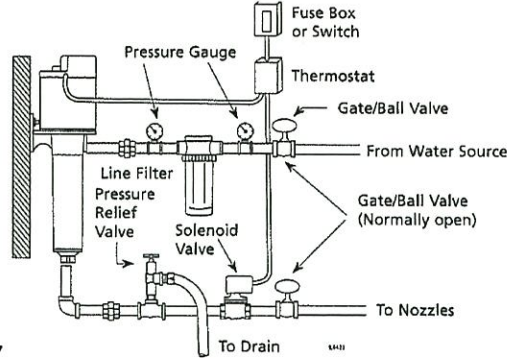

Figure 7

NOTE: Install solenoid valve on discharge side of pump.
IMPORTANT: Clean all filters and strainers on a regular schedule.

Installation (Continued)

⚠ WARNING



Hazardous voltage. Can shock, burn or cause death. Ground pump before connecting to power supply.

⚠ Ground motor before connecting to electrical power supply.

⚠ Failure to ground motor can cause severe or fatal electrical shock hazard.

⚠ Do not ground to a gas supply line.

⚠ CAUTION

Proper rotation of pump impeller is critical on three phase motors. See Motor Rotation under Operation section and Figure 12.

WIRING

1. Install, ground, wire and maintain this pump in accordance with your local electrical code and all other codes and ordinances that apply. Consult your local building inspector for local code information.
2. Ground the pump permanently using a wire of size and type specified by local or United States National Electrical Code. Do not ground to a gas supply line.
3. Connect ground wire first. Connect to ground first, then to green grounding terminal provided on the motor frame, identified as GRD. Ground connection MUST be made to this terminal. Do not connect motor to electrical power supply until unit is permanently grounded; otherwise serious or fatal electrical shock hazard may be caused.
4. Connect the other end of the ground wire to a properly grounded service panel or to a control panel ground bar if it is connected to the power supply ground.

IMPORTANT: Check local and/or United States National Electric Codes for proper grounding information.

CAUTION Make certain that the power supply conforms to the electrical specifications of the motor supplied. See Motor Data Charts.

Pump used to boost incoming pressure from a wall hydrant (manual operation).

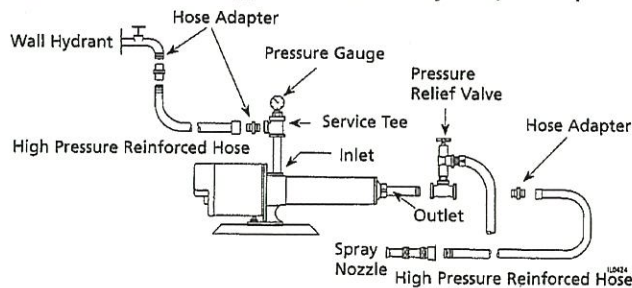
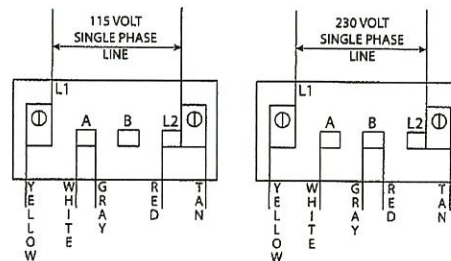
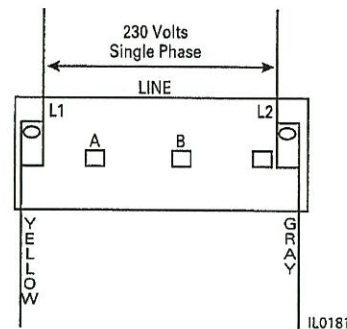

Figure 8



NOTE: Dual voltage motors, change the red and gray wire to the voltage required.

Figure 9 - Wiring Diagram for Single Phase 1/3 - 2 HP Motors



NOTE: Single voltage (230V) motor, and can not be connected to 115V.

Figure 10 - Wiring Diagram for Single Phase 3 HP Motors

Installation (Continued)

3 Phase

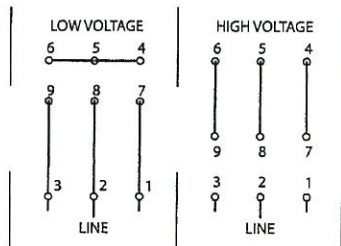

IL1229

Figure 11 - Wiring Diagram for Baldor TEFC 3 Phase motors

3 Phase

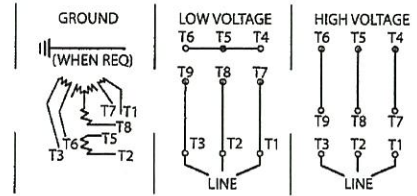

IL1231

Figure 13 - Wiring Diagram for Marathon TEFC 3 Phase motors

3 Phase

1 Phase

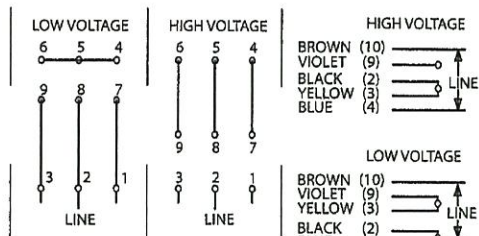

IL1230

Figure 12 - Wiring Diagram for Franklin Electric TEFC 1 Phase and 3 Phase motors

LOW VOLTAGE 230V 3-Ø HIGH VOLTAGE 460 V

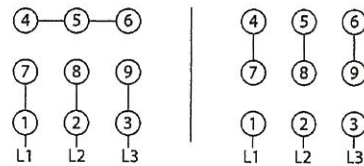

IL0770

- | | | |
|------------|------------|------------|
| 1 - Tan | 4 - Yellow | 7 - Purple |
| 2 - Red | 5 - Black | 8 - Gray |
| 3 - Orange | 6 - Blue | 9 - White |

CONNECTION FOR 3 PHASE, 9 LEADS. IF YOUR 3 PHASE LEADS ARE COLOR CODED, MATCH NUMBER ABOVE TO THE CORRESPONDING COLOR.

NOTE: To reverse rotation, interchange any two incoming lines (Power) leads.

Figure 14 - Wiring Diagram for Three Phase Motors

Installation (Continued)

5. Specific Wiring Procedure (Refer to Figures 9, 10, 11, 12, 13, 14 and Minimum Wire Size Chart).
 - a. Select the voltage you are to use, either 115V or 230V single phase, 230V or 460V three phase.
 - b. The 1/3, 1/2 and 3/4 HP single phase pumps are factory connected for 115V at the motor. The 1, 1½, 2 and 3 HP pumps are factory connected for 230V at the motor. Three phase models are factory connected for 230V at the motor.
 - c. If the motor wiring must be changed to conform to your specific voltage requirements then the motor, pressure switch or other controls should be rewired to conform to one of the wiring diagrams (either 115V or 230V, single phase; 230V or 460V, three phase). Single phase 3 HP motors are 230V only and cannot be wired for 115V service.
- d. The motor wiring diagrams are Figures 9, 10, 11, 12, 13 & 14, and also are located on the motor label of the pump.
6. Remove the rear access cover of the motor.
7. Make the wiring change and replace the rear access cover.

▲ WARNING *Replace rear access cover before starting or operating pump. Failure to do so can result in personal injury.*

IMPORTANT: Do not use an extension cord or splice wires. Joints should be made in an approved junction box. If the above information or the following wiring diagrams are confusing, consult a licensed electrician.

8. All units are **not supplied** with pressure switches, float devices, on/off switches, or the like (control devices). Controls should be wired in at this time, utilizing whatever instructions come with the controls. All units supplied with cords, will run whenever cord is plugged into power and will turn off whenever cord is disconnected from power.

MOTOR PROTECTION

All single phase motors have built in thermal protection for all voltages. The overload protects the motor against burnout from overload of low voltage, high voltage and other causes. The device is automatic and resets itself once the temperature has dropped to a safe point. Frequent tripping of the device indicates trouble in the motor or power lines and immediate attention is needed.

▲ WARNING *Never examine, make wiring changes or touch the motor before disconnecting the main electrical supply switch. The thermal device may have opened the electrical circuit.*

Three phase motors do not have a built in thermal protection. It is recommended that a properly sized magnetic or manual starter (both with properly sized heaters) be used with all three phase motors. Install starters following instructions of the starter manufacturer. See Motor Rotation under Operation Section for changing rotation on three phase motors.

All motors (single and three phase) should be equipped with a correctly fused disconnect switch to provide protection. Consult local or United States National Electric Codes for proper fuse protection based on motor data chart (See Charts C, D and Wire chart F).

Operation

▲ CAUTION *Unit must be full of fluid before operating. Do not run dry, or against a closed discharge. Do not pump dirty water or abrasive liquids. To do so will cause pump failure and will void the warranty.*

VALVES

The inlet valve should be in the full open position and the discharge valve should be partially open, permitting some back pressure to be exerted against the pump when starting up. Open valve after start up is completed.

PRIMING

NOTE: Before starting the pump it is absolutely necessary that **both the pump and the inlet pipe be completely filled with water.**

PRESSURE BOOST INSTALLATIONS

Priming is automatic when pump is connected to a pressure source such as a hydrant or city main (See Figures 6, 7 & 8).

1. Open valves or nozzle on inlet and discharge side of pump.
2. To relieve trapped air, allow water supply to run a minimum of 30 seconds before starting the pump.

IMPORTANT: An adequate flow of water going into the pump is required so that the pumps impellers and shaft seal do not run dry and fail.

3. If you installed a pressure gauge at the pump inlet, a reading of 2 psi minimum should show whenever the pump is in operation (See Figures 6, 7 & 8).

This reading insures that there is an ample supply of water into the pump inlet housing.

MOTOR/PUMP ROTATION

1. Single phase models are one (1) rotation only (counterclockwise when facing the pump end) and cannot be reversed.
2. Proper rotation of pump impeller is critical for three phase pumps. Pump motor should turn counterclockwise (CCW) when facing pump end. Momentarily "bump" (apply power for less than a second) the motor to check for proper rotation. To change rotation on three phase units, interchange any two (2) incoming line (power) leads.

▲ CAUTION *Do not go over recommended maximum operating pressure (see Specifications), while maintaining minimum flow of 1.5*

GPM thru the pump. Do not restrict the inlet line to the pump.

If driver (electric motor) is overloaded, a valve can be installed in the discharge line to increase the back pressure and reduce driver loading.

Operation (Continued)

START - UP PROCEDURE

Once the preceding instructions have been completed, the pump can be started.

1. During the first few hours of operation, inspect the pump, piping and any auxiliary equipment used in connection with the unit.
2. Check for leaks, excessive vibration or unusual noises.

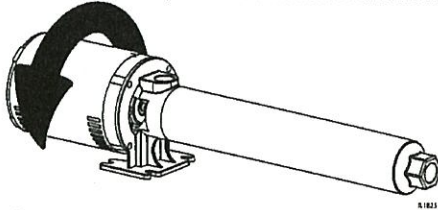

Figure 15 - Correct Motor/Pump Rotation (all units)

NOTE: See rotation arrow on inlet casting.

Maintenance

CAUTION Disconnect power supply and depressurize system before servicing pump or removing any component.

ROUTINE

Pump should be checked routinely for proper operation. Replace or clean all filters and line strainers on a regular basis.

DRAINING

This pump cannot be completely drained because of internal design. Most of the liquid can be drained by tilting the discharge forward after removing discharge casting; or, the liquid can be drained through the inlet port. Store in heated areas.

CLEANING

If used for spraying insecticides, pump should be thoroughly flushed with clean water after using.

LUBRICATION

The motor has prelubricated bearings. No lubrication is required.

SERVICING THREE-PHASE UNITS

Loctite (thread sealer) is used on the threads between the motor shaft and the pump shaft coupling. When reassembling, reapply thread sealer.

PUMP DISASSEMBLY

To disassemble the pump, refer to the exploded parts view and Figures 16, 17 & 18

Tools Required:

- Block of wood (2" x 4" x 12")
 - Piece of 3/4" pipe (12" to 24" long)
 - Pipe wrench
 - Strap wrench
 - 1/4" Dowel rod (about 24" long)
 - 9/16" Open end wrench
 - 3/8" Open end wrench
1. To stabilize pump during disassembly, place block of wood underneath pump barrel.
 2. Thread pipe into pump inlet port. This acts as a handle.
 3. Using the pipe wrench, remove the discharge head, turning CCW (counter clockwise).

4. With the strap wrench, loosen the barrel, turning CCW (counter clockwise). DO NOT use pipe wrench on pump barrel.
5. Holding the impeller stack in place, position pump in upright position, standing unit on the motor end cover. Use the 1/4" dowel rod to hold the stages down and in place on the pump shaft. Remove pump barrel.
7. Slide the stages off the pump shaft onto the 1/4" dowel rod. Leave stages on rod and carefully set aside.
8. Through the side opening of the mounting frame, hold the motor shaft with 9/16" wrench. Remove the shaft and coupling from the motor using the 3/8" wrench on the hex shaped pump shaft.

NOTE: There may be some small .010" shim washers located next to the pump shaft coupling. Keep these shims for re-assembly.

NOTE: If the hex shaft comes free, leaving the coupling attached to the motor, use vise grips to free the coupling.

MECHANICAL SEAL REPLACEMENT

1. Follow instructions under "Pump Disassembly".
2. Remove the mechanical seal assembly.
 - a. The rotary portion of the seal assembly (carbon ring, Buna-N gasket and spring will slide easily off the end of shaft).
 - b. Using two (2) screwdrivers, pry the ceramic seal and rubber gasket from the recess of the mounting ring (See Figure 16).

CAUTION The precision lapped faces of the mechanical seal are easily damaged. Handle the replacement seal carefully.

Short seal life will result if seal faces (ceramic & carbon) are nicked, scratched or dirty.

3. Clean the seal cavity of the mounting ring and the motor thoroughly.
4. Wet outer edge of rubber cup on ceramic seat with liquid soap solution. Use sparingly (one drop only).
- NOTE:** Liquid soap solution - one drop of liquid soap combined with one teaspoonful of water.
5. With thumb pressure, press ceramic seal half firmly and squarely into seal cavity. Polished face of ceramic seat is up. If seal will not seat correctly, remove, placing seal face up on bench. Reclean cavity. Seal should now seat correctly (See Figure 17).
6. If seal does not seat correctly after recleaning cavity, place a cardboard washer over polished seal face and carefully press into place using a piece of standard clean 3/4" pipe as a press (See Figure 18).

Maintenance (Continued)

IMPORTANT: Do not scratch seal face.

7. Dispose of cardboard washer and recheck seal face to be sure it is free of dirt, foreign particles, scratches and grease.
8. Inspect shaft to be sure it is free of nicks and scratches.
9. Apply liquid soap solution sparingly (one drop is sufficient) to inside diameter of rubber rotating member.
10. Slide rotating seal member (carbon face down toward ceramic face) and spring over the shaft.

IMPORTANT: Do not nick or scratch carbon face of seal when handling.

MOTOR REPLACEMENT

The motor can be replaced with any standard Nema 56J jet pump motor (of proper HP for each pump) by referring to the following instructions.

1. Follow steps as outlined under Rotary Seal Replacement and Pump Disassembly.
2. Remove cap screws that connect the motor to the mounting ring and pull motor away.
3. Replace motor with standard Nema 56J jet pump motor by positioning motor against the mounting frame and assembling with four (4) cap screws.

IMPORTANT: Because damage to the shaft seal can occur in disassembly, a new seal will be necessary.

PUMP REASSEMBLY

Before reassembling the pump, carefully inspect the component parts of the cartridge (stage) assembly, looking for damage, wear or heat distortion. Pay careful attention to spacing direction of components, and location of shims. Refer to Figure 19 for proper facing and parts arrangement.

If damage to Stage components is evident, a complete cartridge assembly or individual stage assemblies are available for replacement (See Replacement Parts List).

1. Reassembly should follow the reverse order of the disassembly procedure with special care given to replacement of the rotary seal.
2. Check top and bottom of o-rings for damage. It is recommended that new o-rings be used.
3. Do not use pipe compound or Teflon tape on barrel threads. The o-rings will prevent pump from leaking.
4. After pump is reassembled, tighten the discharge head to a torque of 45-50 ft/lbs. If torque wrench is not available, tighten firmly but avoid distortion or damage to plastic internal parts.
5. After reassembly, apply power momentarily to unit (15 to 30 seconds). The pump and motor should rotate freely or with a light rubbing.

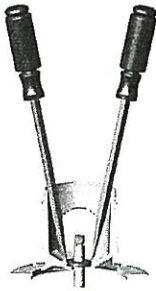

Figure 16 - Remove Mechanical Seal

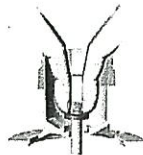

Figure 17 - Press In Seal

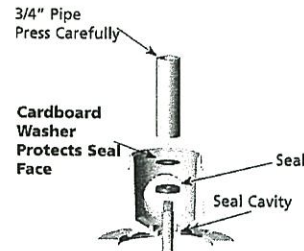

Figure 18 - If Necessary, Press With Cardboard And Pipe

Troubleshooting Chart		
Symptom	Possible Cause(s)	Corrective Action
Pump won't start or run at full speed	<ol style="list-style-type: none"> Blown fuse or open circuit breaker Power supply in OFF position Incorrect voltage at motor (check voltage with motor running) Loose, broken or incorrect wiring Defective motor Pump hydraulic components clogged/worn/damaged 	<ol style="list-style-type: none"> Replace fuse or close circuit breaker. See wire size chart for proper break/fuse size Turn power on Low voltage <ol style="list-style-type: none"> Voltage must be within $\pm 10\%$ of motor rated voltage. Check incoming voltage. Contact power company Make certain that voltage of motor matches voltage of power supply. See motor name plate and motor wiring diagrams Check wire size from main switch to pump. See wire size chart for correct wire size Rewire any incorrect circuits. Tighten connections, replace defective wires Replace motor Replace worn parts or entire pump. Clean parts if required
Pump operates, but delivers little or no water	<ol style="list-style-type: none"> Manual or solenoid valves plumbed into system restricting flow In-line filter restricting flow Low line voltage Inadequate water supply to booster pump Undersized piping Leak on inlet side of system Inadequate, defective or plugged foot valve and/or strainer Worn or defective pump parts or pump. Suction lift too great Pump not primed Incorrect rotation, motor running backwards 	<ol style="list-style-type: none"> <ol style="list-style-type: none"> Check all valves on pump inlet and discharge sides of system to be sure they are opened properly to allow flow to and from the pump Bleed trapped air in pump which keeps water from reaching the pump. (Normally due to closed valve in discharge plumbing) Check all in-line filters to be sure they are not plugged or restricted See low line voltage corrective action (above) Check pressure on inlet side of booster to be sure positive pressure is maintained to the booster pump Replace undersized piping Make sure connections are tight. Repair leaks as necessary Clean, repair or replace as needed Replace worn parts or entire plugged impeller Clean parts if Pump should be operated under flooded suction only Prime pump - Make certain inlet pipe is drawn up tight and pump and pipe are full of water Reverse motor rotation can occur on three phase units. To correct, interchange any two incoming power leads.
Excessive noise while pump in	<ol style="list-style-type: none"> Pump not secured to firm foundation Piping not supported Restricted inlet line Cavitation (noise like marbles in pump) Worn motor bearings 	<ol style="list-style-type: none"> Secure properly Make necessary adjustments Clean or correct <ol style="list-style-type: none"> Reduce speed on direct drive Increase inlet pipe size Too viscous (material being pumped too thick) Replace bearings or motor
Pump leaks	<ol style="list-style-type: none"> Worn mechanical seal (leaks at shaft) Worn o-ring seals 	<ol style="list-style-type: none"> Replace shaft (rotary) seal Replace o-ring seals, located inside both ends of the stainless steel shell

Booster Pump Parts Drawing

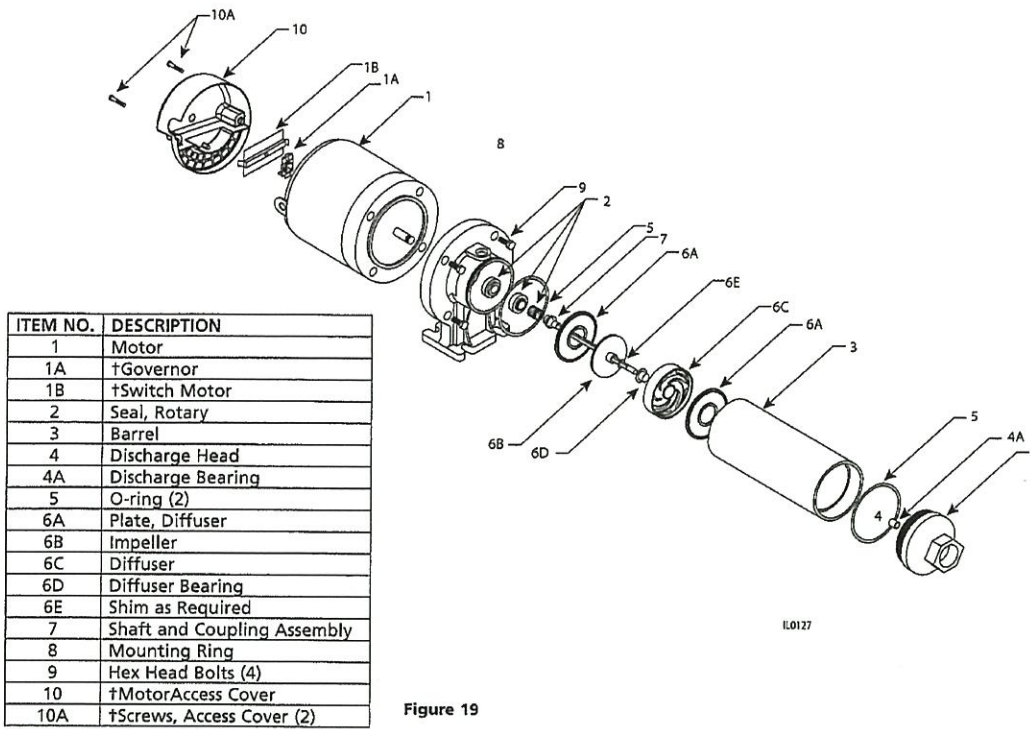

Figure 19

*See note below parts included in cartridge assembly.
†ODP Motor Only

Internal Parts Detail

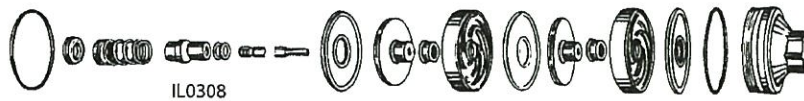
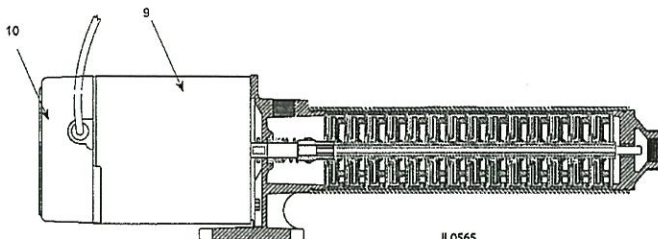

Figure 20 - Cartridge Assembly Includes Discharge Bearing, Shaft & Coupling Assembly, Diffuser Plate, Impellers, Diffuser Bearings, Diffusers and O-rings

NOTE: Illustration shows only two stages. Pump has multiple stages. Individual parts are not available separately.

PRESSURE BOOSTER PUMP REPAIR PARTS
 (For Pricing Refer To Repair Parts Price List)
 Replacement Motors

FORM NO. FW0045
 1114
 SUPERSEDES 0813



IL0565

ITEM	REPLACEMENT MOTORS	QTY	CAST IRON	POWDER COATED	STAINLESS STEEL	CAST IRON	POWDER COATED	STAINLESS STEEL
			SINGLE PHASE 60 HZ			THREE PHASE 60 HZ		
9	ODP NEMA J 1/3 HP	1	98J103	98J103	98S103			
	ODP NEMA J 1/2 HP		98J105	98J105	98S105	98J305	98J305	98S305
	ODP NEMA J 3/4 HP		98J107	98J107	98S107	98J307	98J307	98S307
	ODP NEMA J 1 HP		98J110	98J110	98S110	98J310	98J310	98S310
	ODP NEMA J 1-1/2 HP		98J115	98J115	98S115	98J315	98J315	98S315
	ODP NEMA J 2 HP		98J120	98J120	98S120	98J320	98J320	98S320
	ODP NEMA J 3 HP		98J630	98J630	98S630	023251	023251	023251
10	Motor Cover w/Screws	1	136132R	136132R	136132R	136132R	136132R	
*	Screws, Motor Cover	2	136133	136133	136133	136133	136133	
			SINGLE PHASE 50 HZ			THREE PHASE 60/50 HZ		
9	ODP NEMA J 1/3 HP	1	98J003	98J003	98S003			
	ODP NEMA J 1/2 HP		98J005	98J005	98S005	98J305	98J305	98S305
	ODP NEMA J 3/4 HP		98J007	98J007	98S007	98J307	98J307	98S307
	ODP NEMA J 1 HP		98J010	98J010	98S010	98J310	98J310	98S310
	ODP NEMA J 1-1/2 HP		98J015	98J015	98S015	98J315	98J315	98S315
	ODP NEMA J 2 HP		98J820	98J820	98S820	98J320	98J320	98S320
	10		Motor Cover w/Screws	1	136132R	136132R	136132R	136132R
*	Screws, Motor Cover	2	136133	136133	136133	136133	136133	
			SINGLE PHASE 60/50 HZ			THREE PHASE 60/50 HZ		
9	TEFC NEMA J 1/2 HP	1		020691	020691		021011	021011
	TEFC NEMA J 3/4 HP			021008	021008		021012	021012
	TEFC NEMA J 1 HP			021009	021009		020688	020688
	TEFC NEMA J 1-1/2 HP			020692	020692		020647	020647
	TEFC NEMA J 2 HP			020693	020693		020689	020689
	TEFC NEMA J 3 HP			021010	021010		020690	020690

* Not Shown

FORM NO. FW0046
1114
SUPERSEDES 0312

PRESSURE BOOSTER PUMP REPAIR PARTS (For Pricing Refer To Repair Parts Price List)

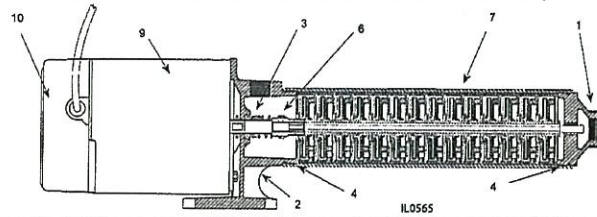

	ITEM	DESCRIPTION	QTY	CAST IRON	POWDER COATED	STAINLESS STEEL	
5 - 7 - 10 - 19 GPM, 60 HZ & 50 HZ	1	Discharge Head 3/4" NPT	1	132000	136806	136840	See replacement motors. ITEMS 9 & 10
	2	Mounting Ring 3/4" NPT	1	132002	136904	136639	
27 - 35 GPM, 60 HZ & 50 HZ	1	Discharge Head 1" NPT	1	136635	137796	139166	
	2	Mounting Ring 1" NPT	1	136634	137794	139100	
55 - 85 GPM, 60 HZ & 50 HZ	1	Discharge Head 2" NPT	1	021585	-	-	
	2	Mounting Ring 2" NPT	1	021584	-	-	
ALL SERIES 60 HZ & 50 HZ	3	Seal, Rotary w/Spring	1	131100 †	131100 †	136682 ‡	
	4	O-Ring	2	131925 ■	131925 ■	136607 ▲	
	*	Hex Head Cap Screws 3/8" x 3/4"	4	121106	121106	121106	

(†) Buna N - Carbon/Silicon Carbide (‡) Viton - Carbon/Silicon Carbide (■) Buna N (▲) Viton (*) Not Shown

60 HZ MODELS	MATERIAL	CAST IRON	CI	PB0508AXXX	PB0512AXXX	PB0516AXXX	PB0712AXXX	PB1014AXXX	PB1016AXXX
		POWDER COATED	PC	PB0508CXXX	PB0512CXXX	PB0516CXXX	PB0712CXXX	PB1014CXXX	PB1016CXXX
		STAINLESS STEEL	SS	PB0508SXXX	PB0512SXXX	PB0516SXXX	PB0712SXXX	PB1014SXXX	PB1016SXXX
	ITEM	DESCRIPTION	MATERIAL	PART NUMBER					
5	Cartridge Assembly ‡	CI & PC	135163	132939	138447	134097	134998	135814	
		SS	136683	138450	136584	136685	136686		
		CI & PC	135161	133336	138446	133336	134996	135813	
6	Shaft & Coupling Assembly	SS	138938	136636	138449	136636	136637	136638	
		CI, PC & SS	135162	132003	138448	132003	134997	135815	
7	Barrel/Shell	CI	137222	135627	136629	136626	136632		
		PC	139162	139163	138946	139164	139165		
		SS	137221	136624	136628	136625	136631		
6	Shaft & Coupling Assembly	CI & PC	137221	136624	136628	136625	136631		
		SS	139159	139157	137535	139156	139158		
7	Barrel/Shell	CI, PC & SS	137223	135628	136630	136627	136633		
50 HZ MODELS	MATERIAL	CAST IRON	CI	PB5504XX	PB5506XX	PB5504XX	PB5506XX		
		POWDER COATED	PC						
		STAINLESS STEEL	SS						
ITEM	DESCRIPTION	MATERIAL	PART NUMBER						
5	Cartridge Assembly ‡	CI & PC	135163	138150	021032	135907		135911	
		SS	138682	021033	138683	020280	138684		
6	Shaft & Coupling Assembly	CI & PC	135161	138149	138149	135906	020278	135910	
		SS	138938	138444	138444	138154	020278	137103	
7	Barrel	CI, PC & SS	135162	138151	138151	135098	020094	135912	
50 HZ MODELS	MATERIAL	CAST IRON	CI	PB1920XXX	PB2717XXX	PB3508XXX	PB3514XXX	PB1922XXX	
		POWDER COATED	PC	PB1920XXX	PB2717XXX	PB3508XXX	PB3514XXX	PB1922XXX	
		STAINLESS STEEL	SS	PB1920YXXX	PB2717YXXX	PB3508YXXX	PB3514YXXX	PB1922YXXX	
ITEM	DESCRIPTION	MATERIAL	PART NUMBER						
5	Cartridge Assembly ‡	CI & PC	020982	020980	136632	021017	139435		
		SS	020095	138949	139165	021026			
6	Shaft & Coupling Assembly	CI & PC	020971	020916	136631	021015	139434		
		SS	020093	138948	139158	021020	021425		
7	Barrel	CI, PC & SS	020094	138947	136633	021016	139436		

(‡) Cartridge assembly includes: impellers, diffusers, o-rings and shaft & coupling assembly. Components not available individually. Sold as assembly only.

LIMITED WARRANTY

The Manufacturer warrants any component or part of the Coleman Hanna Car Wash Systems equipment to be free from defects in material and workmanship for a period of one year from date of shipment, with the exception of such parts as are commonly recognized to be subject to wear in normal usage, such as high pressure hoses, swivels, nozzles, safety shut off guns, etc., which are warranted for ninety (90) days. All electrical parts not manufactured Coleman Hanna Car Wash Systems are warranted to be free from defects in material and workmanship for a period of 90 days. Electrical motors shall be covered under manufacturer's warranty for a period of one year, unless otherwise specified. Coleman Hanna Car Wash Systems electronic controls, such as timers, coin acceptors and computer monitoring equipment, carry a one-year warranty. Claims under this warranty must be asserted in writing within the one-year period covered by this warranty.

Any component or part alleged to be defective in material or workmanship shall, at option of Manufacturer, be returned with shipping cost prepaid. If, upon examination, such component or part is found to be defective in workmanship or materials, Manufacturer, at its option, will either repair or replace such component or part, and shall ship such repaired or replaced component or parts F.O.B. factory, Houston, Texas. Manufacturer reserves the right to use "Like New" or Remanufactured parts in repair of warranty items that exceed 6 months in service. The cost of such replacement or repair shall be the exclusive remedy for any breach of any warranty and Manufacturer shall not be liable to any person for consequential damages for injury or commercial loss resulting from any breach of any warranty. This warrant does not cover any labor installation cost, either with respect to the original equipment, the repaired or replaced component, or part defective in workmanship or materials. Coleman Hanna Car Wash Systems does not warrant loss of income should there be any during such time repairs are being made. Coleman Hanna Car Wash Systems shall not be responsible for vehicle damage or repairs as may arise during normal wash cycle operation. Operator acknowledges accepted risks involved with friction in-bay automatic washes.

This warranty does not apply to components or parts, which have been misused, altered, neglected, not installed, adjusted, maintained, or used in accordance with applicable codes and ordinances and in accordance with Manufacturer's recommendations as to such factors.

THIS WARRANTY IS IN LIEU OF ALL WARRANTIES, EXPRESS OR IMPLIED, OF EITHER MANUFACTURER OR SELLER, AND MANUFACTURER MAKES NO WARRANTY AGAINST INFRINGEMENT OF THE LIKE, MAKES NO WARRANTY OF MERCHANTABILITY, MAKES NO WARRANTY OF FITNESS FOR A PARTICULAR PURPOSE, AND MAKES NO OTHER WARRANTY, EXPRESS OR IMPLIED, INCLUDING IMPLIED WARRANTY ARISING FROM COURSE OF DEALING OR USAGE OF TRADE.

This warranty does not apply to damage resulting from improper operation or abuse, exceeding the rated capacities of the unit, running foreign particles or non related solutions through pumps or valves, using acidic solutions, improper installation or maintenance, operational neglect, neglect of manufacturers recommended maintenance, use of water containing solids in excess of twenty microns in diameter or 2000 PPM, damage caused by customer, unjustifiable nuisance calls, or acts of God.

Compliance with any local governmental laws or regulations relating to the location, use or operation of the equipment, or its use in conjunction with other equipment, shall be the responsibility of the purchaser. The rights and obligations of the parties shall be governed by the State of Texas.